

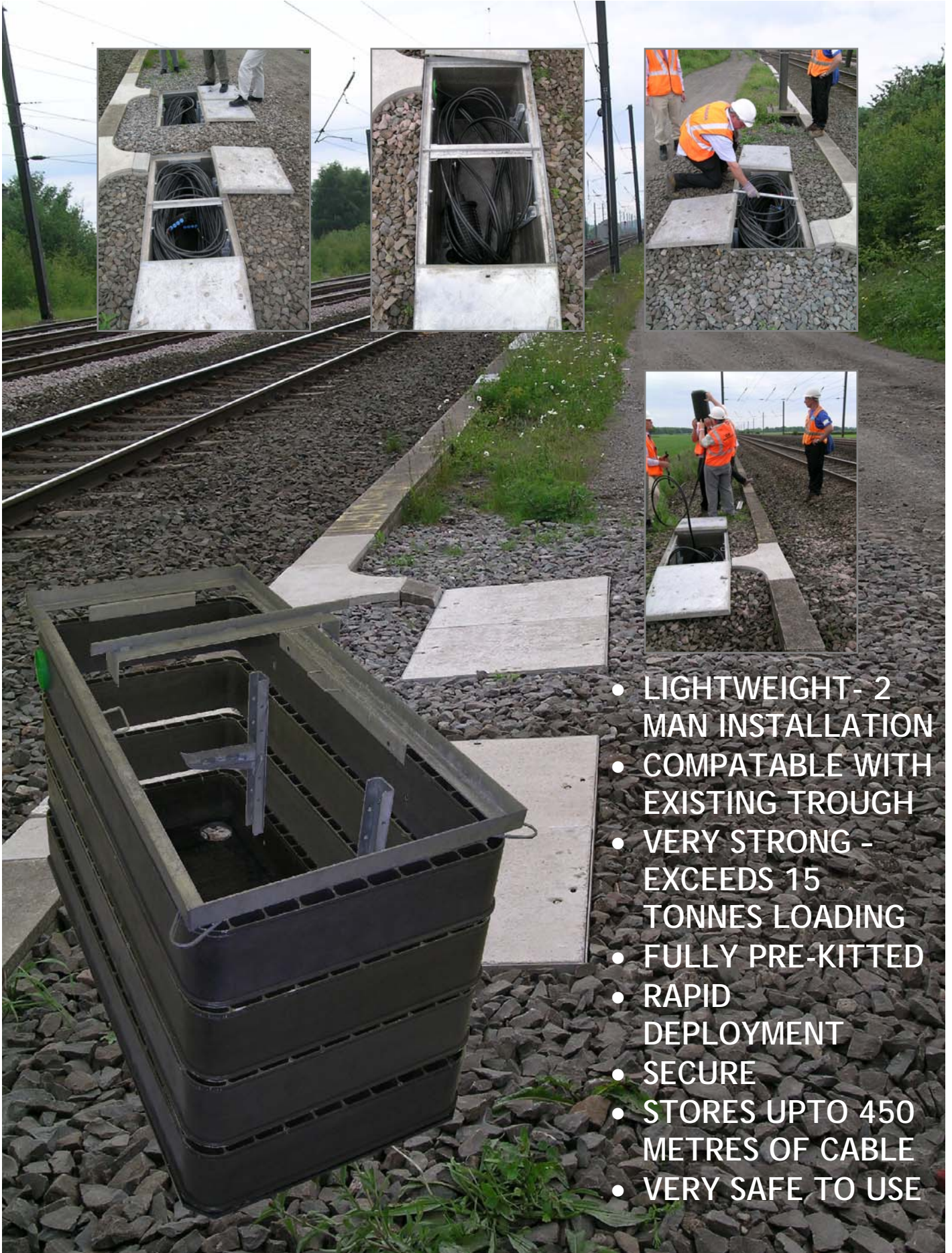

STAKKAbOX™

NETWORK RAIL FIBRE JOINT CHAMBER



- LIGHTWEIGHT- 2 MAN INSTALLATION
- COMPATABLE WITH EXISTING TROUGH
- VERY STRONG - EXCEEDS 15 TONNES LOADING
- FULLY PRE-KITTED
- RAPID DEPLOYMENT
- SECURE
- STORES UPTO 450 METRES OF CABLE
- VERY SAFE TO USE



STAKKAbOX™ NETWORK RAIL FIBRE JOINT CHAMBER

COMPARISON TO CONCRETE TROUGH		
CONCRETE	VS	STAKKAbOX™
+ 200Kgs	TOTAL WEIGHT	128Kgs
5 Hours	INSTALLATION TIME	35 Minutes
8	MEN TO LIFT (HSE GUIDE 25Kgs/ MAN)	2
5 Metres	CABLE LENGTH CAPACITY	450 Metres
No	SECURITY FITTED AS STANDARD	Yes
Yes	SPECIAL PLANT REQUIRED ON SITE	No

The STAKKAbOX™ offers Network Rail network contractors the ability to construct Fibre Joint Bays and other equivalent underground access chambers, very quickly, very safely and very economically.

In addition; the tried and tested design of the STAKKAbOX™ means that when installed; the unit will provide years of service for Network Rail. The STAKKAbOX™ is not affected by diesel, ground acids, alkalines or frost – all known killers of concrete and as a structural unit it will support loadings imparted from vehicles and passing trains.

Safety on site will continue to be good as longer cable lengths held in the chamber allow service work to be carried out on the joint well away from the track and access to the chamber can be made by one man when composite covers are installed.

SPECIFICATION

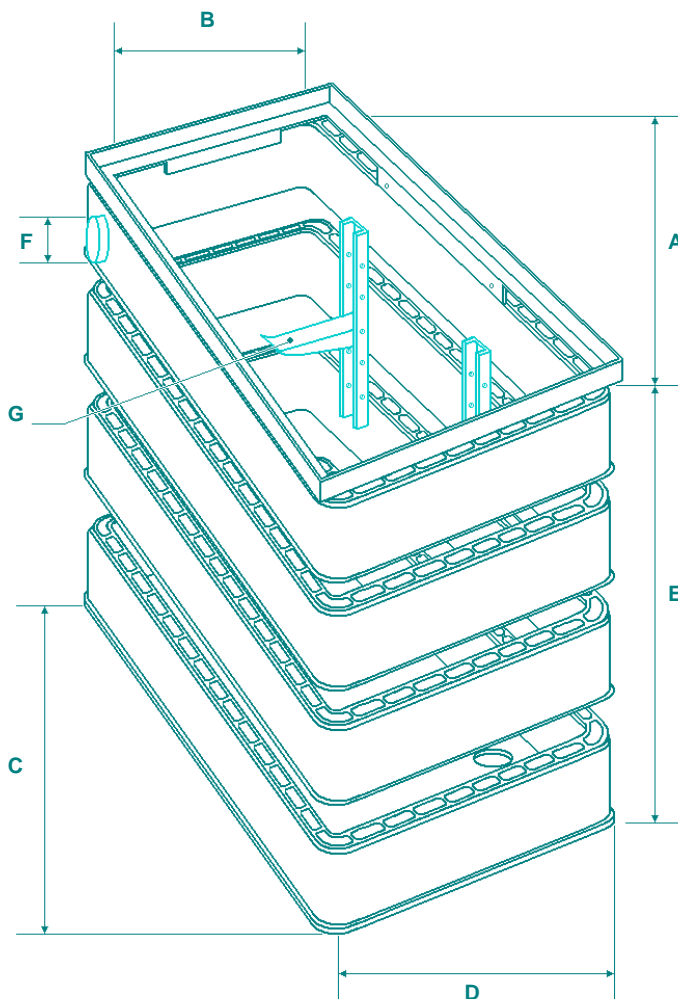

COVER & FRAME

OPTION 1

Composite EN124 B125 Double locking lids, 610mm x 610mm, galvanised steel frame (bolted to chamber top)

INDIVIDUAL COVER WEIGHT: 20Kgs

TOTAL COVERS WEIGHT: 58Kgs

OPTION 2

Concrete infill EN124 B125 Double locking lids, 610mm x 610mm, galvanised steel frame (bolted to chamber top)

INDIVIDUAL COVER WEIGHT: 58Kgs

TOTAL COVER WEIGHT: 129Kgs

CHAMBER

SECTION DEPTH: 150mm

SECTION WEIGHT: 14Kgs

CLEAR OPENING

A: LENGTH 1310mm

B: WIDTH 610mm

OVERALL SIZE

C: LENGTH 1410mm

D: WIDTH 710mm

E: DEPTH 450mm, 600mm (shown) or 750mm

BASE 11mm thick and complete with drainage hole, WEIGHT: 12Kgs

ACCESSORIES

CHAMBER ENTRY BELLMOUTH

F: INTERNAL DIAMETER 110mm

JOINT BEARER BRACKETS x 2

G: WALL CHANNEL LENGTH 508mm

ARM LENGTH 263mm

TOTAL WEIGHT: 3.8Kgs

ORDER CODE 1002406 (600mm DEEP C/W CONCRETE INFILL COVERS)